

Low Frequency Transistor(50V,3A)

2SC4672

FEATURES

- Low saturation voltage: $V_{CE(sat)}=0.1V$ at $I_C/I_B=1A/50mA$.
- Excellent DC current gain characteristics.
- Complements the 2SA1797.

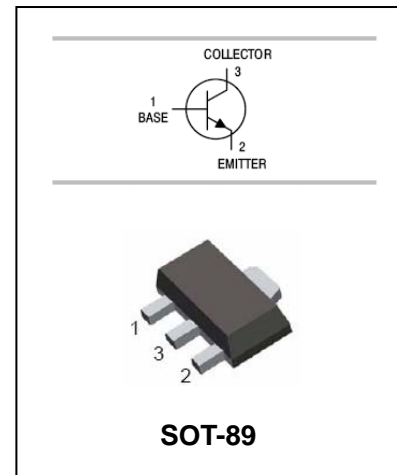

APPLICATIONS

- Power amplifier application.

ORDERING INFORMATION

Type No.	Marking	Package Code
2SC4672	DKP/DKQ	SOT-89

MAXIMUM RATING @ $T_a=25^{\circ}C$ unless otherwise specified

Symbol	Parameter	Value	Units
V_{CBO}	Collector-Base Voltage	60	V
V_{CEO}	Collector-Emitter Voltage	50	V
V_{EBO}	Emitter-Base Voltage	6	V
I_C	Collector Current (DC) Collector Current (Pulse)	2 5	A
P_C	Collector Dissipation	500	mW
T_j, T_{stg}	Junction and Storage Temperature	-55 to +150	$^{\circ}C$



Low Frequency Transistor(50V,3A)

2SC4672

ELECTRICAL CHARACTERISTICS @ Ta=25°C unless otherwise specified

Parameter	Symbol	Test conditions	MIN	TYP	MAX	UNIT
Collector-base breakdown voltage	$V_{(BR)CBO}$	$I_C=50\mu A, I_E=0$	60			V
Collector-emitter breakdown voltage	$V_{(BR)CEO}$	$I_C=1mA, I_B=0$	50			V
Emitter-base breakdown voltage	$V_{(BR)EBO}$	$I_E=50\mu A, I_C=0$	6			V
Collector cut-off current	I_{CBO}	$V_{CB}=60V, I_E=0$			0.1	μA
Emitter cut-off current	I_{EBO}	$V_{EB}=5V, I_C=0$			0.1	μA
DC current gain	h_{FE}	$V_{CE}=2V, I_C=0.5A$	82		270	
		$V_{CE}=2V, I_C=1.5A$	45			
Collector-emitter saturation voltage	$V_{CE(sat)}$	$I_C=1A, I_B=50mA$		0.1	0.35	V
Transition frequency	f_T	$V_{CE}=2V, I_E=0.5A, f=100MHz$		210		MHz
Collector output capacitance	C_{ob}	$V_{CB}=10V, I_E=0, f=1MHz$		25		pF

CLASSIFICATION OF h_{FE}

Rank	P	Q
Range	82-180	120-270
MARKING	DKP	DKQ

TYPICAL CHARACTERISTICS @ Ta=25°C unless otherwise specified

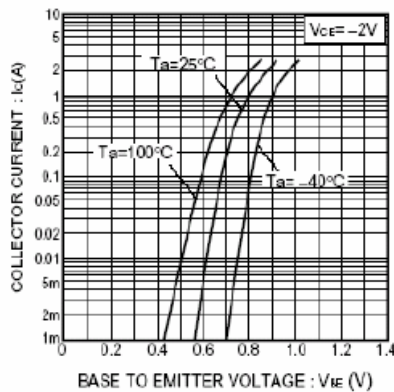

Fig.1 Grounded emitter propagation characteristics

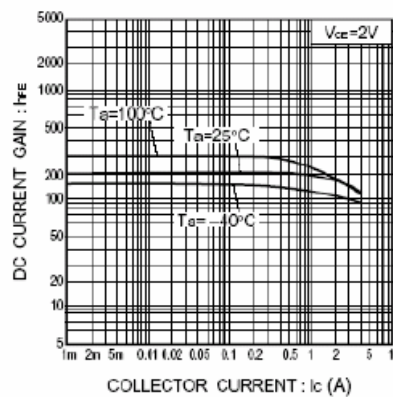

Fig.2 DC current gain vs. collector current

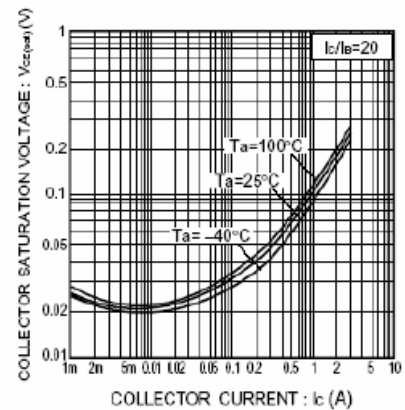

Fig.3 Collector-emitter saturation voltage vs. collector current



Low Frequency Transistor(50V,3A)

2SC4672

PACKAGE OUTLINE

Plastic surface mounted package

SOT-89

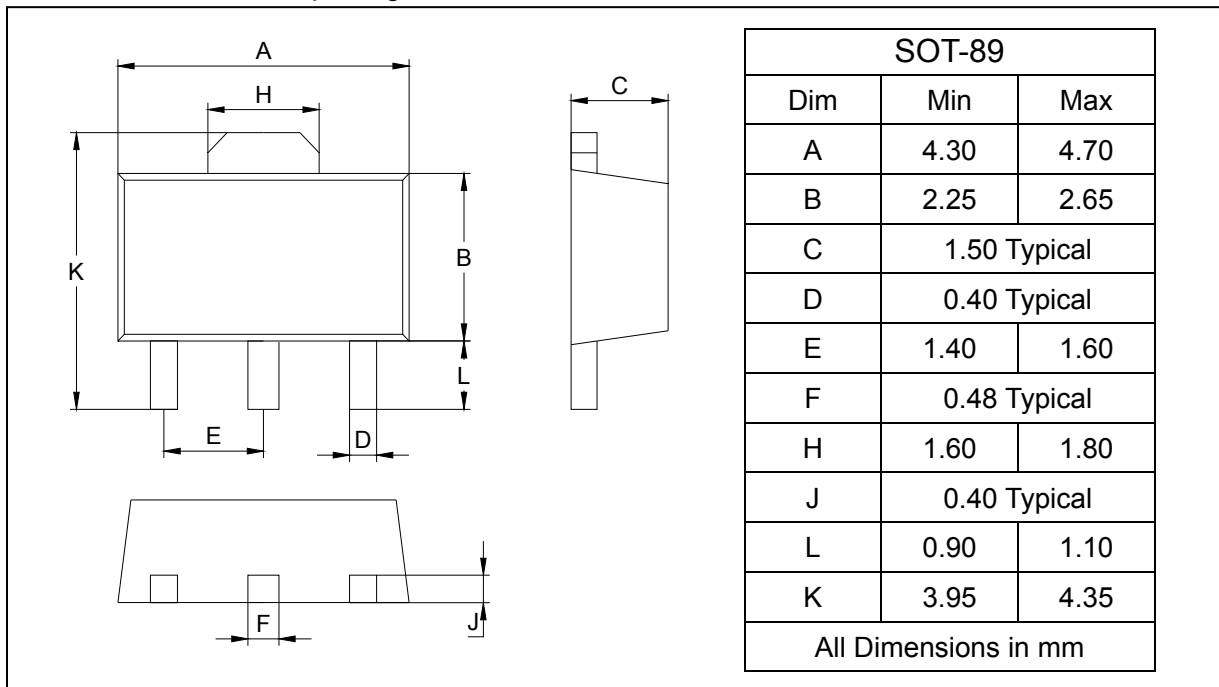

SOLDERING FOOTPRINT

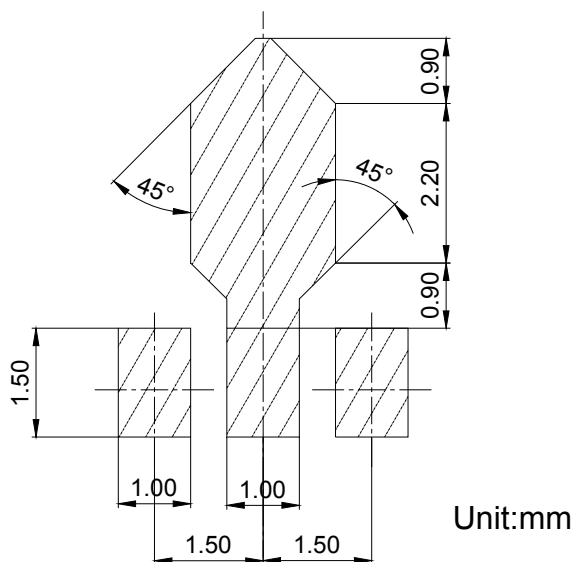

PACKAGE INFORMATION

Device	Package	Shipping
2SC4672	SOT-89	1000/Tape&Reel